

## SERIES OF HYBRID STEPPING MOTOR

### 混合式步进电机 四相高转矩低振动方形 86BYGH450 系列



#### 基本参数 (General Specifications):

步距角 (Step Angle)	----- 1.8° /0.9° (full step/ half step)
步距角精度 (Step Angle Accuracy)	----- ±5% (full step, no load)
电阻精度 (Resistance Accuracy)	----- ±10%
电感精度 (Inductance Accuracy)	----- ±20%
温升 (Temperature Rise)	----- 80°C Max (rated current, 2 phases on)
环境温度 (Ambient Temperature Range)	----- -20°C ~ +50°C
绝缘电阻 (Insulation Resistance)	----- 100MΩ Min. 500VDC
绝缘介电强度 (Dielectric Strength)	----- 750VAC 50Hz 1mA 1 Minute
绝缘等级 (Insulation Class)	----- B 级 (130°C 级)
轴向变形 (Shaft Axial Play)	----- 0.08mm Max (450g Load)
径向跳动 (Shaft Radial Play)	----- 0.02mm Max (450g Load)
最大径向力 (Max. radial force)	----- 220N (20mm from the flange)
最大轴向力 (Max. axial force)	----- 60N
旋转方向 (Rotation)	----- CW (See From Front Flange)

#### 主要参数 (Electrical Specifications):

型号 Model	机身长L Motor Length (mm)	保持转矩 Holding Torque (N.m)		电压 Rated Voltage (V)	电流 Rated Current (A)	电阻 Phase Resistance (Ω)	电感 Phase Inductance (mH)	转动惯量 Rotor Inertia (kg.cm <sup>2</sup> )	引出线数 Lead Wire	定位力矩 Detent Torque (N.m)	重量 Motor Weight (kg)
		两相	一相								
86BYGH450A-01	70.5	3.4	2.6	2.4	2	2.6	9.5	1	8	0.12	2.1
86BYGH450A-02	70.5	3.4	2.6	3.6	3	1.2	4.0	1	8	0.12	2.1
86BYGH250A-01	70.5	3.4	2.6	4.8	4	0.8	4.8	1	4	0.12	2.1
86BYGH250A-02	70.5	3.4	2.6	6.4	5.9	0.28	1.7	1	4	0.12	2.1
86BYGH450B-01	101.5	7.28	5.2	2.4	2	4.2	20	2.7	8	0.24	3.3
86BYGH450B-02	101.5	7.28	5.2	1.8	3	1.8	7.5	2.7	8	0.24	3.3
86BYGH250B-01	101.5	7.28	5.2	4.8	4	1.4	20	2.7	4	0.24	3.3
86BYGH250B-02	101.5	7.28	5.2	2.4	6	0.5	4.8	2.7	4	0.24	3.3
86BYGH450C-01	130.5	10.2	7.8	6.4	2	5.8	30	4	8	0.36	4
86BYGH450C-02	130.5	10.2	7.8	6.4	4	0.45	7.5	4	8	0.36	4
86BYGH250C-01	130.5	10.2	7.8	3.2	4	1.7	7.0	4	4	0.36	4
86BYGH250C-02	130.5	10.2	7.8	2.5	6	0.55	4.5	4	4	0.36	4
86BYGH450D-01	162.5	13.57	10.4	2.72	2	7.0	42	5.1	8	0.48	5.5
86BYGH450D-02	162.5	13.57	10.4	4.8	3	4.4	21	5.1	8	0.48	5.5
86BYGH450D-03	162.5	13.57	10.4	14	4	3.5	10	5.1	8	0.48	5.5
86BYGH250D-01	162.5	13.57	10.4	3.6	4	2.1	14.5	5.1	4	0.48	5.5
86BYGH250D-02	162.5	13.57	10.4	4.8	6	0.65	6.0	5.1	4	0.48	5.5

\*以上产品为基本型，可根据用户要求订做派生：轴伸、电流、高低温、密封等

## 接线图 (Wiring Diagram):

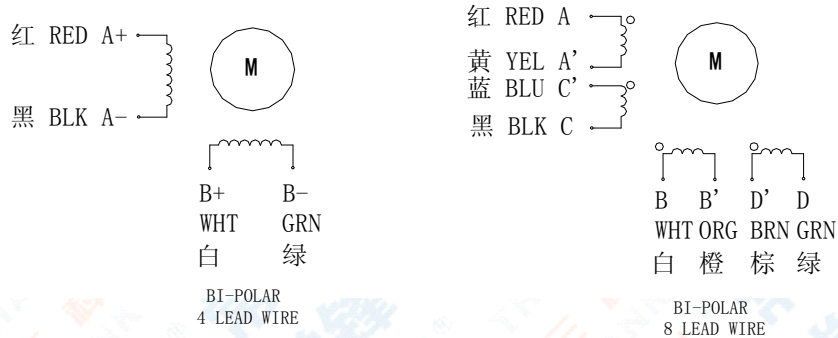

## 外形图 (Dimensions):

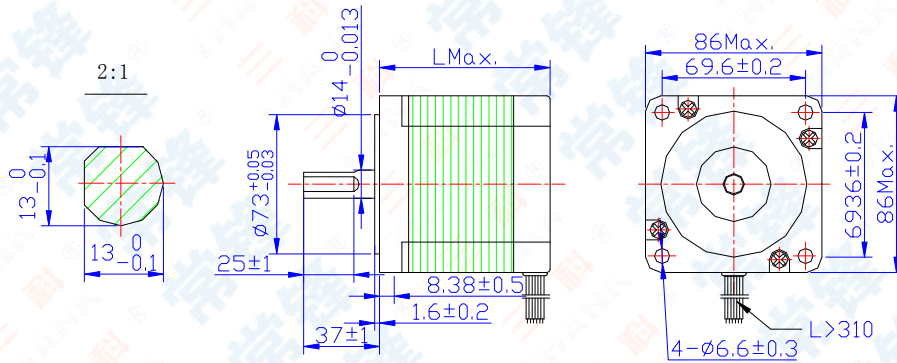

86BYGH450/A/B/C/D, 86BYGH250A/B/C/D

## 运行矩频特性 (Pull-out Torque-pulse curve):

